

UNIFORM STATUTORY DECLARATION FORM FOR THE REGISTRATION OF FITTING DESIGNS

NEW BRUNSWICK
NUNAVUT

NOVA SCOTIA
YUKON

PRINCE EDWARD ISLAND
NORTHWEST TERRITORIES

NEWFOUNDLAND AND LABRADOR

MANUFACTURERS NAME: Swagelok Company	
MANUFACTURERS ADDRESS: 29500 Solon Road, Solon, Ohio 44139 USA	
PLANT LOCATIONS: Headquarters: 29500 Solon Road, Solon, Ohio 44139 USA (See Attachment A)	
CATEGORY OF FITTINGS TO BE REGISTERED. CIRCLE ONE CATEGORY ONLY <input checked="" type="radio"/> A Pipe fittings, including couplings, tees, elbows, Ys, plugs, unions, pipe caps, or reducers <input type="radio"/> B Flanges: all flanges <input type="radio"/> C Valves: all line valves <input type="radio"/> D Expansion joints, flexible connections, and hose assemblies: all types <input type="radio"/> E Strainers, filters, separators, and steam traps <input type="radio"/> F Measuring devices, including pressure gauges, level gauges, sight glasses, levels, or pressure transmitters <input type="radio"/> G Certified capacity-rated pressure relief devices acceptable as primary over pressure protection on boilers, pressure vessels, piping and fusible plugs <input type="radio"/> H Pressure retaining components that do not fall into one of the above categories <input type="radio"/> I Nuclear components: Class 1 <input type="checkbox"/> Class 2 <input type="checkbox"/> Class 3 <input type="checkbox"/> (Meeting AECB or ASME requirements)	TITLE OF THE STANDARD OF CONSTRUCTION ASME B31.1 for unlisted components, ASME B31.3 for unlisted components
SHOW MANUFACTURERS NAME, TRADEMARK, OR LOGO AS IT WILL APPEAR ON THE PRODUCT 	TYPE OF CONSTRUCTION FORGED <input checked="" type="checkbox"/> WELDED <input type="checkbox"/> WROUGHT <input checked="" type="checkbox"/> CAST <input type="checkbox"/> OTHER <input type="checkbox"/> DESCRIBE OTHER:
LIST OF SUPPORTING DOCUMENTATION AND IDENTIFICATION OF THE ACTUAL ITEMS TO BE REGISTERED: ISO 9001:2015 Certificate, Attachment A, Attachment B, Catalog Information and other Support Documents	

DECLARATION:

I, Joel Feldman, Vice President, Engineering (see note 3) employed by Swagelok Company and being the person having full authority and responsibility for the quality of the end product do solemnly declare that the information contained in this form is true and to the best of my knowledge represents the product for which registration is sought. The dimensions, materials of construction, pressure temperature ratings, and identification markings are in accordance with the herein named standards. I further declare that the manufacture of these fittings is regulated by a Quality Control Program which extends to each plant where fabrication occurs in whole or in part and has been verified by BSI as being suitable for that purpose and I make this solemn declaration conscientiously believing it to be true, and knowing that it is of the same force and effect as if made under oath.

Signature of Declarer: Joel C. Feldman
 Declared before me at Solon, Ohio
 This 3rd day of October AD 2019
 Commissioner of Oaths or Notary Public: (sign) Bryan J. Hamel
 (Affix Official seal to the right)

USE THIS SPACE FOR THE
OFFICIAL SEAL

This space for Regulatory Authority use This registration must be revalidated after <u>10</u> years from the date of expiration and	NUNAVUT Nunavut Pressure Vessels Act REGISTERED CRN <u>0A22314, SN</u> Date <u>May 14, 2020</u> Signed <u>[Signature]</u> Chief <u>Michael Leung</u> Director Safety Services - CGS
CRN: <u>0A22314.5</u> FID#: <u>1214</u> Alloy 600 (ASTM B166, B564) Tube Fittings. Note: For B166 N06600 material the annealed bar allowable stresses are used. Notes: 1. All fittings shall be registered in the name of the Manufacturer. 2. Each category shall be supported with two Statutory Declaration forms and one copy of supporting documentation. 3. The declaration shall be made by the person having full authority and responsibility for the quality of the end product. 4. Quality control programs shall be resubmitted for validation at a maximum interval of five (5) years. CRN expires April 3, 2030 - DG	Territorial Registration Fee



**Attachment B. Scope of Registration for Swagelok Alloy 600
 (ASTM B166, B564) Tube Fittings (Category A)**

This document represents the scope of Swagelok Inconel Alloy 600 Tube Fittings covered by this submission for CRN approval. These Swagelok Tube Fittings have been evaluated in accordance with ASME B31.3 for unlisted components and ASME B31.1 for unlisted components.

THIS IS PART OF CRN
 0A22314.5
 Technical Standards and Safety Authority
 Boilers and Pressure Vessels Safety
 Program

Summary Table

Product Description or Series	Material (Standard)	Port Connections and Sizes	Maximum Allowable Working Pressure		Design Code of Construction
			Up to 100°F	At maximum temperature	
Gaugeable Tube Fittings and Adapter Fittings	Alloy 600 (ASTM B166 / ASTM B564)	Swagelok End Connection 1/4, 3/8, 1/2 inch 6mm, 10mm, 12mm	See Table below	See Table below	ASME B31.1 (Unlisted Components) ASME B31.3 (Unlisted Components)
			NPT Male 1/16 - 1 inch	11 000 – 5300 psig	8800 - 4240 psig @ 900°F (482°C)
		11 000 – 5300 psig		3300 - 1590 psig @ 1000°F (537°C)	ASME B31.3 (Unlisted Components)
		NPT Female 1/16 - 1 inch	6700 – 4400 psig	5360 - 3520 psig @ 900°F (482°C)	ASME B31.1 (Unlisted Components)
			6700 – 4400 psig	2010 - 1320 psig @ 1000°F (537°C)	ASME B31.3 (Unlisted Components)

Alloy 600 Swagelok Tube Fitting Pressure Rating Table

Swagelok End Connection Size	Maximum Allowable Working Pressure		
	Up to 100°F	At maximum temperature 900°F (482°C) ASME B31.1	At maximum temperature 1000°F (537°C) ASME B31.3
1/4	10 200 psig	5814 psig	3570 psig
3/8	6500 psig	3705 psig	2275 psig
1/2	5100 psig	2907 psig	1785 psig
6mm	670 bar	381 bar	234 bar
10mm	380 bar	216 bar	133 bar
12mm	310 bar	176 bar	108 bar

Product Description

Swagelok Fittings are furnished in a variety of configurations and shapes (straight, elbow, tee or cross). Swagelok Fittings consist of at least one Swagelok End – a proprietary two-ferrule mechanical-grip design. The table below, as well as the “Configurations” section, covers a variety of other end connections.

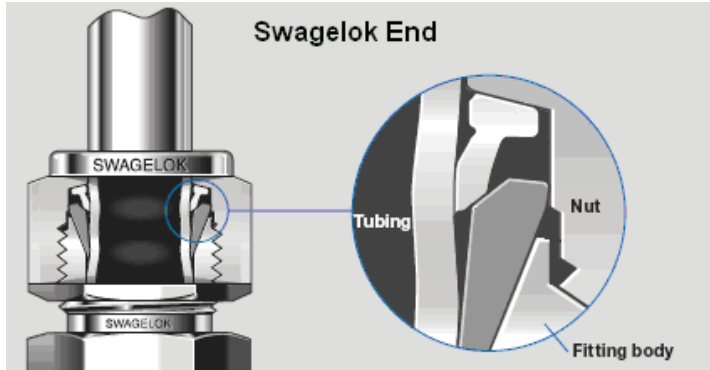

THIS IS PART OF CRN
 0A22314.5
 Technical Standards and Safety Authority
 Boilers and Pressure Vessels Safety
 Program

Configurations

1. Unions.

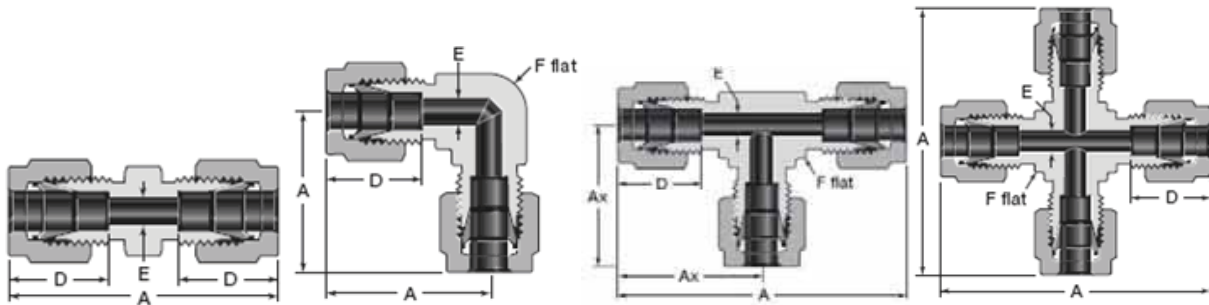

2. Male and Female connectors / adapters.

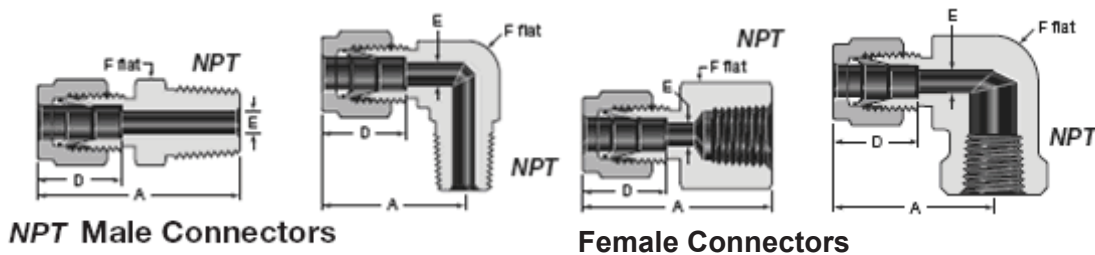

Product Options:

Some of the product options listed below affect the pressure-temperature ratings in the “Scope of Registration” section above, but in all cases the pressure ratings are the same or less than those shown in the Summary Table on page 1.

- Tapered pipe thread (NPT) sealant:
 - Curable resin with PTFE
 - PTFE tape
- Bored through fittings
- Plastic ferrules, (Nylon, Teflon, PEEK)

Additional options that do not affect pressure and/or temperature ratings may be made available within the scope of this approval. Examples of these would include the following:

- Special marking
- Special cleaning
- Wire drills
- bulkhead configurations
- Snubbers/frits and orifice plates

All of the above options, those that affect pressure and/or temperature ratings and those that do not, are within the scope of this approval.

Quality System

The Swagelok Company quality system complies with the requirements of ISO 9001:2015. Swagelok Company maintains BSI Certificate of Registration Number FM 01729, which applies to all locations listed on the Certificate.

THIS IS PART OF CRN
0A22314.5
Technical Standards and Safety Authority
Boilers and Pressure Vessels Safety
Program

References

The product catalog does not represent the full scope of the registration but rather details some of the most common options.

- Gaugeable Tube Fittings and Adapter Fittings MS-01-140, Rev Y
- Swagelok Tubing Data Sheet MS-01-107, Rev N

Attachment A. Swagelok Manufacturing Locations

This document lists the Swagelok locations where end item or component level manufacturing activities take place.

THIS IS PART OF CRN
 0A22314.5
 Technical Standards and Safety Authority
 Boilers and Pressure Vessels Safety
 Program

Swagelok Company 29500 Solon Road Solon, Ohio 44139 USA	Swagelok Company (Falon 1) 348 Bishop Road Highland Heights, Ohio 44143 USA
Swagelok Company (Highland) 318 Bishop Road Highland Heights, Ohio 44143 USA	Swagelok Company (Falon 2) 358 Bishop Road Highland Heights, Ohio 44143 USA
Swagelok Company (OFC) 29495 F.A. Lennon Drive Solon, Ohio 44139 USA	Swagelok Company (HPF) 6050 Cochran Road Solon, Ohio 44139 USA
Swagelok Company (Atlantic) 26651 Curtiss Wright Parkway Willoughby Hills, Ohio 44092 USA	Swagelok Company (Snow Metal) 6060 Cochran Road Solon, Ohio 44139 USA
Swagelok Company (Micro) 26653 Curtiss Wright Parkway Willoughby Hills, Ohio 44092 USA	Swagelok Company (Alfred) 29500 Ambina Drive Solon, Ohio 44139
Swagelok Hose Services Company (SHSC) 29900 Solon Industrial Parkway Solon, Ohio 44139	Swagelok Company (Strongsville) 15400 Foltz Road Strongsville, Ohio 44119
Swagelok (China) Fluid System Technologies Ltd. Changshu Export Process Zone Changshu Economic Development Zone Changshu, Jiangshu 215513 China	Swagelok Limited Ballafletcher Road Tromode IM4 4RA Isle of Man