

UNIFORM STATUTORY DECLARATION FORM FOR THE REGISTRATION OF FITTING DESIGNS

NEW BRUNSWICK
NUNAVUT

NOVA SCOTIA
YUKON

PRINCE EDWARD ISLAND
NORTHWEST TERRITORIES

NEWFOUNDLAND AND LABRADOR

MANUFACTURERS NAME: <u>Swagelok Company</u>	
MANUFACTURERS ADDRESS: <u>29500 Solon Road, Solon, Ohio 44139-3492</u>	
PLANT LOCATIONS: <u>Headquarters: 29500 Solon Road, Solon, Ohio 44139-3492 (See Attachment A)</u>	
<p align="center">CATEGORY OF FITTINGS TO BE REGISTERED. CIRCLE ONE CATEGORY ONLY</p> <p><input checked="" type="radio"/> A Pipe fittings, including couplings, tees, elbows, Ys, plugs, unions, pipe caps, or reducers</p> <p><input type="radio"/> B Flanges: all flanges</p> <p><input type="radio"/> C Valves: all line valves</p> <p><input type="radio"/> D Expansion joints, flexible connections, and hose assemblies: all types</p> <p><input type="radio"/> E Strainers, filters, separators, and steam traps</p> <p><input type="radio"/> F Measuring devices, including pressure gauges, level gauges, sight glasses, levels, or pressure transmitters</p> <p><input type="radio"/> G Certified capacity-rated pressure relief devices acceptable as primary over pressure protection on boilers, pressure vessels, piping and fusible plugs</p> <p><input type="radio"/> H Pressure retaining components that do not fall into one of the above categories</p> <p><input type="radio"/> N Nuclear components: Class 1 <input type="checkbox"/> Class 2 <input type="checkbox"/> Class 3 <input type="checkbox"/> (Meeting AECB or ASME requirements)</p>	<p align="center">TITLE OF THE STANDARD OF CONSTRUCTION</p> <p>ASME B31.3 Chapter IX, for unlisted components where applicable</p>
SHOW MANUFACTURERS NAME, TRADEMARK, OR LOGO AS IT WILL APPEAR ON THE PRODUCT	
Swagelok	<p align="center">TYPE OF CONSTRUCTION</p> <p>FORGED <input type="checkbox"/> WELDED <input type="checkbox"/> WROUGHT <input checked="" type="checkbox"/> CAST <input type="checkbox"/> OTHER <input type="checkbox"/> DESCRIBE OTHER:</p>
LIST OF SUPPORTING DOCUMENTATION AND IDENTIFICATION OF THE ACTUAL ITEMS TO BE REGISTERED:	
Attachment A, Attachment B, Support Documents, Catalog Information, ISO 9001:2008 Quality System Certificate Items To Be Registered: Swagelok IPT Series Fittings	

DECLARATION:

I, David H. Peace (see note 3) employed by Swagelok Company and being the person having full authority and responsibility for the quality of the end product do solemnly declare that the information contained in this form is true and to the best of my knowledge represents the product for which registration is sought. The dimensions, materials of construction, pressure temperature ratings, and identification markings are in accordance with the herein named standards. I further declare that the manufacture of these fittings is regulated by a Quality Control Program which extends to each plant where fabrication occurs in whole or in part and has been verified by The British Standards Institution as being suitable for that purpose and I make this solemn declaration conscientiously believing it to be true, and knowing that it is of the same force and effect as if made under oath.

Signature of Declarer: [Signature]

Declared before me at Solon, Ohio

This 14th day of January AD 2010

Commissioner of Oaths or Notary Public: (sign) [Signature]
(Affix Official seal to the right)

USE THIS SPACE FOR THE OFFICIAL SEAL

Jarmo L. Ristau
Resident Portage County
Notary Public, State of Ohio
My Commission Expires: 03/06/2010



<p align="center">This space for Regulatory Authority use This registration must be revalidated after ten (10) years from the date of acceptance.</p> <p>CRN: <u>0A18288.5</u></p> <p>FID#: <u>1214</u></p> <p>Notes: 1. All fittings shall be registered in the name of the Manufacturer. 2. Each category shall be supported with two Statutory Declaration forms and one copy of supporting documentation. 3. The declaration shall be made by the person having full authority and responsibility for the quality of the end product. 4. Quality control programs shall be resubmitted for validation at a maximum interval of five (5) years.</p>	<p align="center">NUNAVUT Boilers and Pressure Vessels Act</p> <p align="center">REGISTERED</p> <p>CRN <u>0A18288.5N</u></p> <p>Date <u>April 08, 2010</u></p> <p>Signed <u>[Signature]</u> Chief Inspector</p> <p align="center">Territorial Registration Fee</p>
--	---

Attachment B: Scope of CRN Registration for Swagelok Cone and Thread IPT Fittings (Category A)

This document represents the scope of the Swagelok Cone and Thread IPT Fittings covered by this submission for CRN approval. The Swagelok Cone and Thread IPT Fittings were designed and evaluated in accordance with ASME B31.3 Chapter IX for unlisted components.

Summary Table

Product Description	Materials	End Connections	Sizes	Maximum Rated Pressure (psi)		Design Code of Construction
				At ambient temperature	At maximum temperature (1000F)*	
Cone and Thread Fittings – IPT Series	316 SS A276 or A479	Medium-Pressure Cone and Thread	1/4"	20000	16800	ASME B31.3 Chapter IX (unlisted components)
			3/8"	20000	16800	
			9/16"	20000	16800	
			3/4"	20000	16800	
			1"	20000	16800	

*Max temperature pressure ratings were obtained by multiplying the medium pressure working rating listed in the product catalog by the listed elevated temperature factor for Strain-Hardened 316 SS (0.84)

Product Illustration

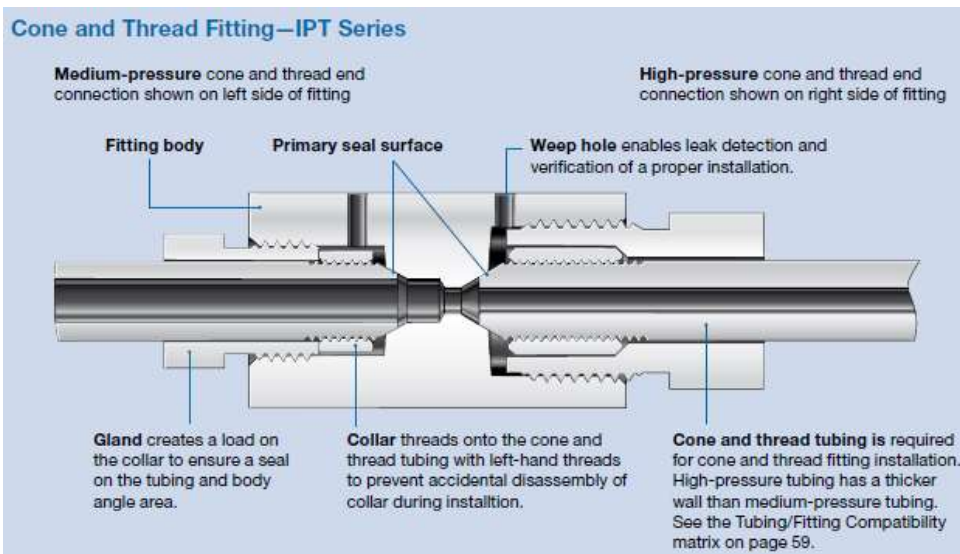

Configurations

Couplings

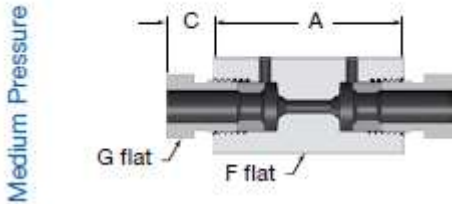

Elbows

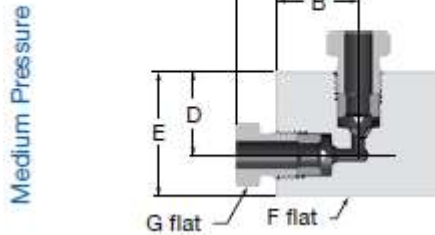

Tees

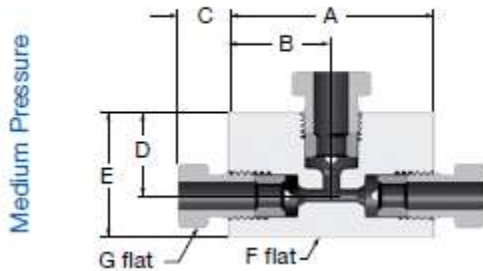

Crosses

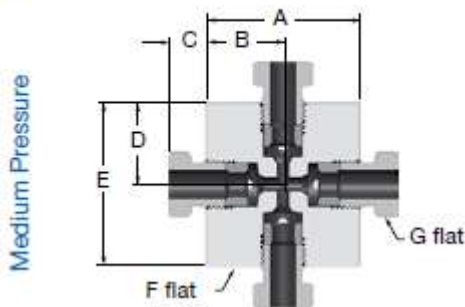

Caps and Plugs

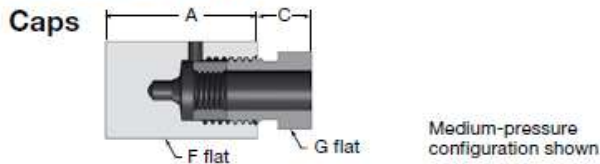

Plugs

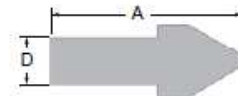

Typical Product Characteristics

Some product options could affect the pressure-temperature ratings shown in the Summary Table, but in all cases the ratings are less than or equal to those shown in the Summary Table. An example of this would be collars, glands, or tube nipples.

Additional options that do not affect pressure-temperature ratings may be made available within the scope of this registration.

Quality System

The Swagelok Company quality system complies with the requirements of BS EN ISO 9001:2008. The Swagelok Company maintains British Standards Institution Certificate of Registration Number FM 01729, which applies to all locations listed on the Certificate. IPT Fittings are manufactured at a Swagelok Company location in Erie, Pennsylvania.

References

The product catalog does not represent the full scope of registration, but rather details some of the most common options.

- Medium and High Pressure Valves, Fittings and Tubing Catalog MS-02-472